

INSTALLATION OF LARGE LOCKABLE COVER

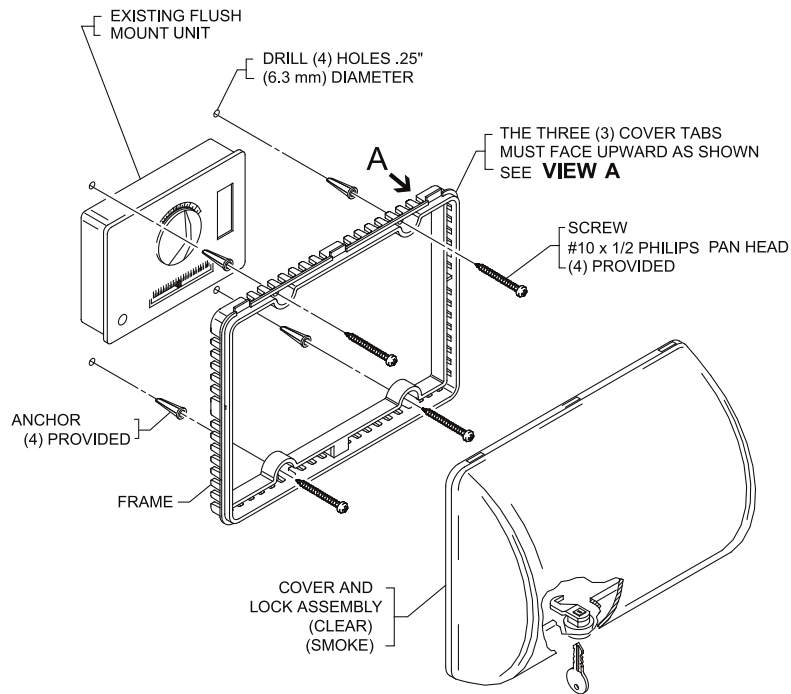

FLUSH MOUNT

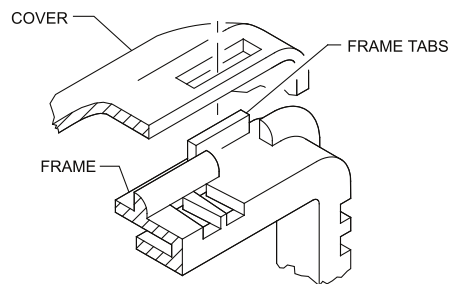

VIEW A

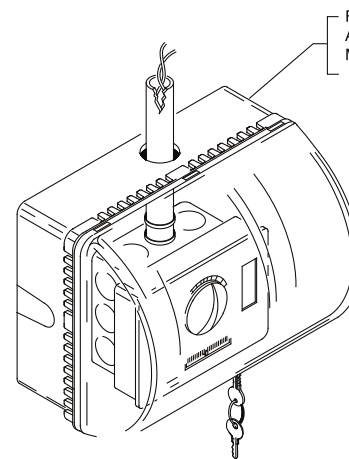

FOR SURFACE MOUNT

FOR ADEQUATE CLEARANCE
A 2 in. (50mm) DEEP SPACER
MUST BE USED

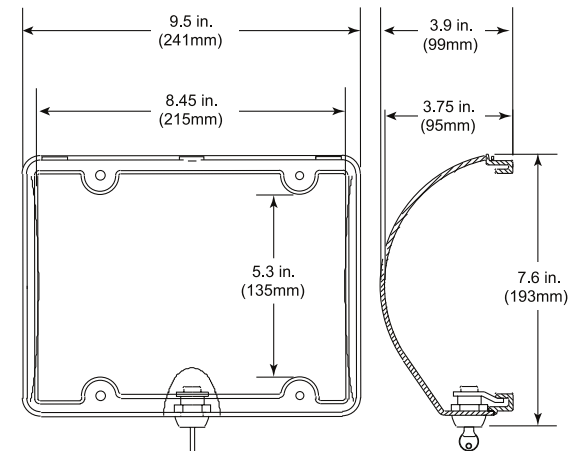

INSTALLATION INSTRUCTIONS

- Center frame over existing unit. Mark and drill (4) anchor holes using a 1/4 in. (6.3mm) drill bit. Insert the (4) anchors and complete installation as shown.

NOTE: The (3) tabs on the frame must face upward (View A).

- Insert the (3) slots on the cover over tabs on the top surface of frame. Rotate cover downward onto the frame and turn key to lock.

CLEANING INSTRUCTIONS

To clean cover, remove from wall. Rinse with water to remove abrasive dust and dirt. Wash with soap or mild detergent using a soft cloth (DO NOT SCRUB). Rinse once more, then dry with a soft cloth or chamois. To remove grease or wet paint, rub gently with a cloth wetted thoroughly with naphtha. Then wash and rinse. DO NOT USE RAZOR BLADES.